

See discussions, stats, and author profiles for this publication at: <https://www.researchgate.net/publication/341532578>

Geotechnical Engineering

Chapter · January 2020

DOI: 10.1016/B978-0-12-409548-9.12508-4

CITATIONS

7

READS

1,790

3 authors, including:



Bryant Andrew Robbins

Institute for Water Resources - U.S. Army Corps of Engineers

56 PUBLICATIONS 207 CITATIONS

SEE PROFILE

Some of the authors of this publication are also working on these related projects:



Backward Erosion Piping: Mechanics and Modeling [View project](#)



Soil erosion [View project](#)

Geotechnical Engineering

BA Robbins, IJ Stephens, and WF Marcuson III ,

© 2020.

Introduction	1
Site Characterization	2
Desk Study	2
Preliminary Site Investigation	2
Detailed Site Investigation	2
In situ testing	2
Drilling and sampling	3
Soil property determination	3
Design	4
Foundations	4
Shallow foundations	4
Deep foundations	7
Slopes and Embankments	8
Dams and Levees	9
Retaining Walls	10
Dewatering	11
Tunneling	12
Offshore Structures	12
Soil Dynamics	12
Rockfalls and Landslides	12
Ground Improvement	13
Construction	13
Foundation Inspection	14
Earthwork Control	14
Erosion Control and Drainage	14
Future Directions	14
Education	14
Technology	15
Conclusions	15
References	15
Further Reading	16

Introduction

Engineering started with the first humans trying to either improve and/or defend their cave. Engineering began to subdivide with innovation and creativity into such disciplines as civil, mechanical, electrical, chemical, industrial and, recently, materials engineering, bio-engineering and computer engineering. Geotechnical engineering is a sub-discipline of civil engineering and can be defined as the use of earth material (soil and rock) for improving and defending society and life.

In ancient times, dikes and levees were constructed along the Nile, Tigris and Euphrates, Yellow and Indus Rivers. The purpose of these structures was to protect nearby settlements from flooding and to irrigate crops. Up until about 1700, geotechnical engineering was a succession of practical experiments without any scientific underpinning. Geotechnical engineering activity was devoid of theoretical foundation, but instead relied on intuition which came from observation and careful reflection. That being said, buildings in Venice, the richest and most powerful city in mediaeval Europe, used fairly elaborate foundations (Kerisel, 1985).

As discussed in the review by Skempton (1985), some of the first publications on geotechnical engineering date from the middle 1800s and early 1900s. Rankine published his work on stability of loose soil in 1857. Important work by Darwin and Boussinesq led to the definition of the internal angle of friction. Real advancement in the knowledge of geotechnical engineering started in the early 1900s with work on soil classification by Atterberg. Bell published his practical work on shear testing of soil in 1915, and Fellenius and his colleagues published simple methods of slope stability analysis between 1916 and 1926. Karl Terzaghi, the man known as the “Father of Soil Mechanics”, published his work on consolidation and shear strength around 1925.

Geotechnical engineering, as we know it today, began about a century ago. The first international conference on soil mechanics and foundation engineering, conceived and organized by Arthur Casagrande (Peck, 1985), was held at Harvard University in 1936.

Topics reported on included shear strength, undisturbed sampling, in situ testing, estimating settlement, consolidation theory, regional subsidence, soil improvement, swelling clays, frost action and soil dynamics.

In the following sections geotechnical engineering is discussed under the broad categories of site characterization, design, construction, and future directions. Because of space limitations, some important topics in geotechnical engineering are omitted. For example, discussion regarding optimum water content for compaction, swelling and shrinking soils, and undrained versus drained soil shear strengths are not addressed.

Site Characterization

Before design on a project with a geotechnical engineering component can begin, an understanding of the context or setting where it will be constructed is necessary. The design engineer will be required to make certain assumptions or predictions about the ground conditions that can be complex and varied, hence it is quite useful to have a local engineer involved who has regional, site specific experience. A sound approach to site characterization will greatly improve design assumptions, reduce uncertainty, and increase confidence in the expected performance of the structure. The best geotechnical investigations employ a phased approach, where each step in the investigation is informed and guided by the previous information collected. This process generally consists of:

- (i) A desk study of geology and soils data followed by site reconnaissance,
- (ii) A preliminary site investigation identifying the general depth, thickness, and composition of soils, and site hydrogeology;
- (iii) A detailed site investigation providing quantitative soils data from measurements; and
- (iv) Perpetual monitoring and observation to verify site conditions and the project design.

For smaller projects, some of these steps may be combined or undertaken concurrently, while larger, more complex projects may require multiple iterations between steps as key variables are defined, analyzed and reinvestigated. Regardless of scale, this phased approach results in more relevant, higher quality data that lead to an optimized design and reduced project costs.

Desk Study

The desk study is the beginning point for a geotechnical site investigation and can yield significant information. The scope of the desk study can vary depending on the scale of the project, but the overall purpose is to determine what is already known about the site, and what special considerations need to be taken as the investigation develops. For small projects in a familiar area, the engineer's experience may be all that is needed for this step. However, for most projects, a desk study will generally consist of a review of regional and local geology, information available from nearby borings or wells, as well as information that can be gleaned from maps, areal imagery or other geographic data. Additionally, regional seismology, seismic hazard analysis, and site response (attenuation relationships) to seismic loadings may be studied. These datasets can provide important information regarding potential geologic hazards, general subsurface conditions, site access, groundwater levels, and past uses of the site and surrounding area. This information is compiled to form a general understanding of the site. The following steps build on this to further define the site conditions.

Preliminary Site Investigation

Preliminary site investigations are used to build on and fill gaps found in the desk study. Collection of aerial imagery or limited soil sampling may be performed. Often, non-invasive techniques, such as geophysical surveys, are used as they yield continuous data over larger areas with limited effort. Geophysical techniques rely on the detection of contrasts in different physical properties of soil and rock to identify subsurface conditions. Because of this, different methods relying on various physical properties, including compression or shear wave velocity, electrical resistivity, self-potential (the naturally existing electric current in the earth), gravity, and magnetic susceptibilities, can be used to evaluate stratigraphy, depth to rock, water table location, and fault locations. Geophysical investigations can also identify anomalies; such as, a perched water-table and/or pockets of gas, that might otherwise be missed by discrete sampling techniques and can thus be a useful tool in planning drilling locations. The results of a geophysical investigation can vary greatly depending on the techniques applied, so using the appropriate method and understanding its limitations are crucial to obtaining information that will be useful in future phases.

Detailed Site Investigation

In situ testing

Several in situ tests can be used to measure soil properties as they exist in place, without the need to extract soil samples from the ground and transport them to a laboratory for testing. There are many cases where this is preferable to collecting samples to be tested later in the laboratory, and in some instances, relative density for loose sands for example, may be the only economical way to determine certain soil properties. Some examples of in situ tests include the standard penetration test (SPT), described below, the cone penetration test (CPT), field vane or vane shear test, dilatometer, pressure meter, and well pumping tests. The CPT consists of pushing a cone (**Fig. 1**) on the end of a series of rods into the ground at a constant rate using a hydraulic ram. Sensors in the tip of the cone and along the side of the rod measure the resistance of the soil to the penetration of the cone. Often the pore water pressure is measured as well. These measurements are correlated to various soil properties, including soil type and strength. The CPT is a useful tool because continuous measurements

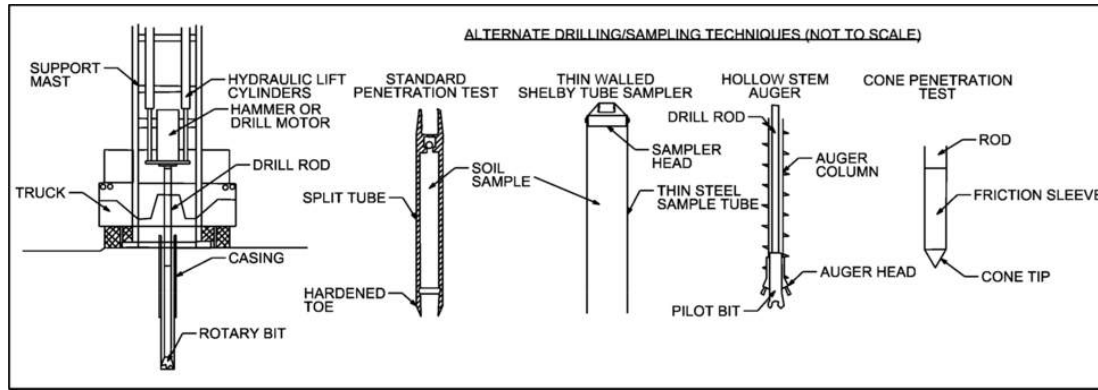

Fig. 1 Illustrations of invasive site characterization techniques. Not to scale. After Fell R, MacGregor P, Stapledon D, Bell G, and Foster M, (2005). *Geotechnical Engineering of Dams*. CRC Press, Dunicliff J and Green GE (1993). *Geotechnical Instrumentation for Monitoring Field Performance*. John Wiley & Sons, and Hunt RE (1984). *Geotechnical Engineering Investigation Manual* (No. 624.151 H86). New York: McGraw-Hill.

with depth are obtained very quickly, as contrasted with sampling at discrete depths using other drilling techniques. Soil properties can also be estimated from correlations using CPT data without extracting material for separate laboratory tests.

Drilling and sampling

Drilling allows for visual identification and classification of the soils at a site while providing opportunities for sample collection. Information from previous phases is used to identify discrete locations where it is necessary to verify/correct the site model and obtain soil samples for laboratory testing. Collection of soil samples for visual identification and laboratory testing is done by drilling holes from the surface or by digging test pits or trenches. Several different technologies exist to drill holes, the most common being rotary wash and hollow-stem augers (**Fig. 1**). Samples collected by boring are generally classified as disturbed and undisturbed. Disturbed samples have their structure and density altered, usually by vibration or impact caused by the method used to collect the sample. These samples can be used for classification purposes and for the determination of some properties that are not changed by the disturbance, but many properties such as void ratio, permeability, compressibility, and strength will be altered. One of the most common methods of collecting disturbed samples is as part of the Standard Penetration Test (SPT) (**Fig. 1**). This is a standardized test that provides a crude, in-place measurement of strength and density while also collecting a disturbed sample of soil. The test consists of driving a split-spoon or barrel sampler by dropping a weight (63.5 kg/140 lb) a standard height (76.2 cm/30 in.) onto a series of rods connected to the sampler at the bottom of the bore hole. The number of drops required to advance the probe the last 12 in. (30.5 cm) of an 18-in. (45.7 cm) drive is recorded as the N-value. Profiles of the N-value with depth can then be used to identify certain properties of each soil layer.

Soil property determination

Properties of interest

Several soil properties are of interest to the geotechnical engineer. It is important to realize that soil is made up of varying combinations of solid minerals, water, air, and sometimes organic material. A complete definition of all significant soil properties and their interrelated aspects could, and does, fill many textbooks on the subject. This article notes the key properties for routine engineering analyses. Some properties are a function of size and composition of the solids, while others are related to the structure and density of the soil. The most important of these properties are listed in **Table 1**.

Estimated soil properties

Several systems have been developed to identify and describe soils based on certain engineering characteristics. The most commonly used classification systems in geotechnical engineering are the Unified Soil Classification System (USCS) and the American Association of State Highway and Transportation Officials (AASHTO) Soil Classification System.

The USCS divides soils into three major classification groups: (i) coarse-grained soils (e.g., sands and gravels), (ii) fine-grained soils (e.g., silts and clays), and (iii) highly organic soils (peat). In coarse-grained soils more than 50% of the particles by weight are larger than 0.074 mm in diameter (i.e., will be retained by a No. 200 sieve). If more than 50% by weight will pass through a No. 200 sieve, then the soil is classified as fine-grained. From these three broad groups, soils are further refined into 15 more precisely defined sub-groups. For coarse-grained materials, distinctions are made based on the distribution of particle sizes. For fine-grained materials, the size of individual particles has less impact on the engineering behavior of the soil, so tests relating moisture content, soil strength and plasticity are used. These tests, known as *Atterberg Limits*, are used to differentiate between silts and clays, both of which can be classified as either highly plastic or not. **Fig. 2** illustrates the USCS for inorganic soils, as well as the general engineering behavior that can be expected for each soil classification type.

Table 1 Important engineering properties of soil.

<i>Property</i>	<i>Symbol</i>	<i>Significance</i>
Hydraulic conductivity	K	Indicates how readily water can flow through the soil
Void ratio	e	Ratio of volume of voids (air and water) to volume of solids per unit volume of soil. Related to the soil density
Density	ρ	Mass per unit volume
Degree of saturation	S	Related to water content, it is the ratio of the volume of water in the soil voids, to the total volume of voids (air and water)
Specific gravity	G_s	Density of dry soil particles (solid fraction) divided by the density of water
Soil particle size	D	Major factor in soil classification. The distribution, or gradation of particle sizes, influences strength, permeability, and erosion characteristics of soil
Water content	w	Defined as the weight of water per unit volume divided by the weight of the dry soil per unit volume. Influences a wide range of soil properties in both coarse- and fine-grained soils from strength and unit weight, to stiffness and ductility

The current AASHTO system began in the 1920s as the Public Roads Classification System (Holtz and Kovacs, 1981). This system is based on the soil's behavior under highway pavements and classifies them into groups, A-1 through A-10, that generally progress from coarser (A-1) to finer (A-8). For further details, the interested reader is referred to **Holtz et al. (2011)** and **Das (1979)**.

Properties from laboratory tests

A wide variety of laboratory tests can be performed on soil samples to measure engineering properties. It is important to note that samples tested in a laboratory are of a very small scale relative to the field conditions that the engineer is attempting to analyze, and scale can have a significant effect on the measurement of certain properties (e.g., permeability measured in the laboratory can be orders of magnitude too low).

Laboratory tests can be divided into tests on disturbed or undisturbed samples. Disturbed samples are easier to collect and are used for tests where the properties being measured are not impacted by changes to the structure or state of the soil sample. Examples include tests for measuring water content, particle size, specific gravity, Atterberg limits, and compaction properties. While it is not possible to obtain truly undisturbed samples, the term is used to describe samples that have retained most of their in situ characteristics. Undisturbed samples are required for tests that are used to determine properties related to the structure and state of the soil as it exists in the ground. Tests measuring strength, void ratio and permeability are examples of tests that require undisturbed samples.

Design

Once a thorough characterization has been conducted at a site, the soil types, extents, and engineering properties of interest should be well understood and visually portrayed in profile and cross-section drawings of the site. With this information in hand, a geotechnical engineer must then design engineering works to reliably serve their purpose under all anticipated conditions the structure will reasonably be exposed to during the selected design life. The design criteria for geotechnical aspects of engineering projects are typically focused on controlling either (i) excessive soil deformation and/or (ii) water flowing through the soil. The following sections provide a brief overview of the design approach taken for major geotechnical projects.

Foundations

Foundations are an integral component of all civil engineering projects. Bridges, buildings, highways, and energy infrastructure must all rest on some type of foundation. When discussing foundations, the primary issue of concern from a design perspective is controlling soil deformation. That is, a foundation must only exhibit an acceptable amount of deformation (both vertically and laterally) under the specific design load. In general, foundations of structures may be divided into two major categories: (i) shallow foundations and (ii) deep foundations (**Das, 2007**). Shallow foundations consist of foundations such as strip footings, spread footings, and mat foundations, whereas deep foundations consist of foundations such as piles and drilled shafts. An example of a typical shallow foundation and deep foundation is shown in **Fig. 3**.

Shallow foundations

Shallow foundations refer to all foundations placed within a limited depth of the ground surface designed to convey a load through a contact pressure with the underlying soil. A shallow foundation must be designed such that it: (i) is safe against an overall shear failure (described below), and (ii) will carry its design loads without exhibiting excessive displacements.

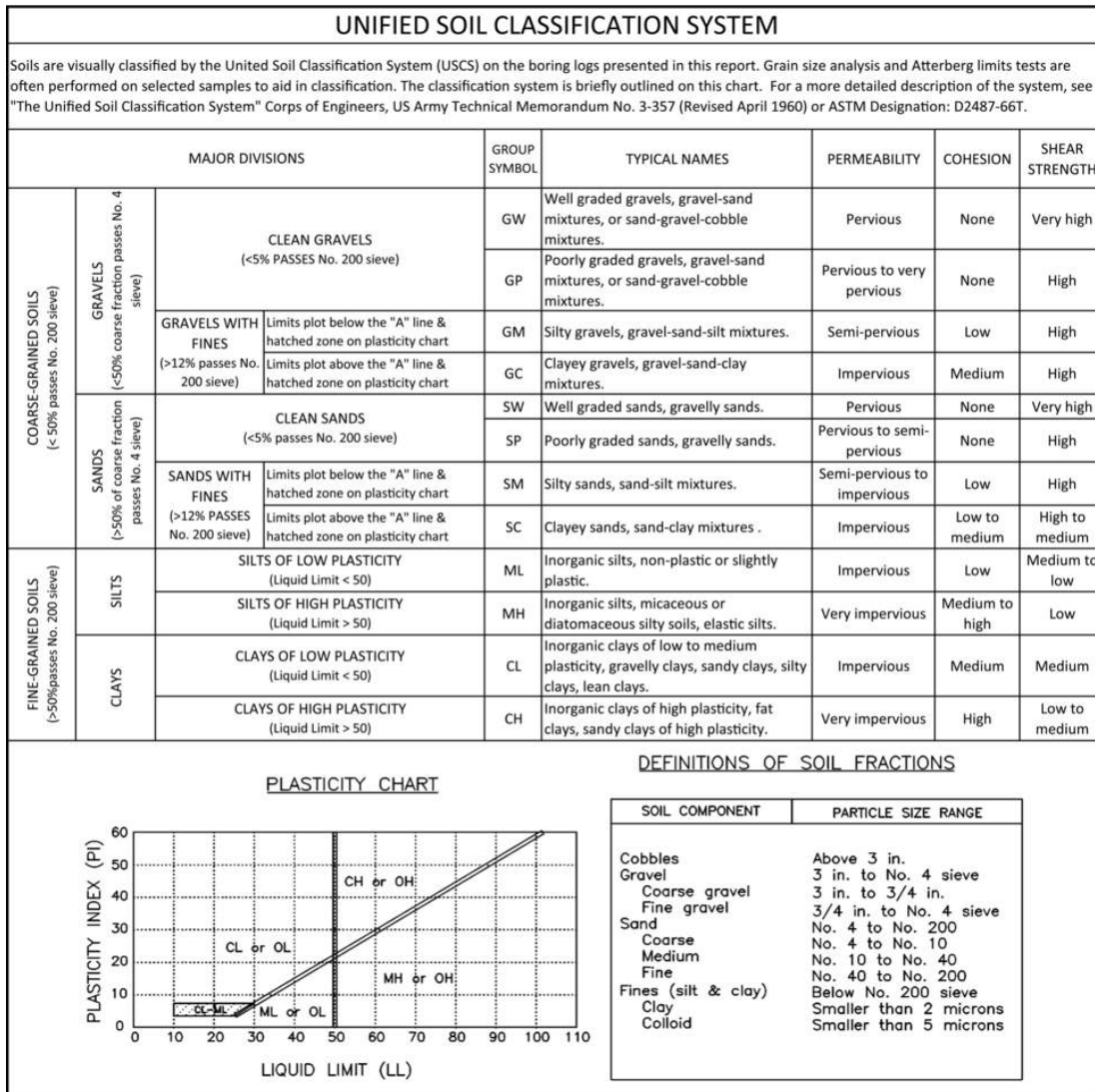

Fig. 2 Unified Soil Classification System (USCS).

To ensure safety against overall shear failure, the footing loads must not exceed the ultimate bearing capacity of the soil (q_u). To assess the expected displacements under service loads, the elastic settlement and consolidation of the soil under the anticipated loads must be considered.

Ultimate bearing capacity

Consider a typical strip footing as shown in Fig. 4. The footing has a width of B and is embedded to a depth of D_f . The bearing area applies a contact pressure q to the soil below the footing. In general, any foundation for which $D_f < 3B$ can be considered a shallow footing (Das, 2007). As illustrated in Fig. 4B, if an increasing load is applied to the footing, the footing will settle gradually until the ultimate bearing capacity, q_u , is reached. At the ultimate bearing capacity, the shear strength of the soil, τ , is exceeded along the failure surface ADEI (or CDFJ), and the soil mass moves and rotates along the failure plane leading to the uncontrolled displacement of the foundation (shear failure). An example of this type of failure at the ultimate bearing capacity of the soil is illustrated in Fig. 5.

The general equation for predicting the ultimate bearing capacity of shallow foundations consists of a combination of theoretical and empirical factors, given by Meyerhof (1963) as:

$$\begin{aligned}
 q_u = & c' N_c F_{cs} F_{cd} F_{ci} + \gamma D_f N_q F_{qs} F_{qd} F_{qi} \\
 & + \frac{1}{2} \gamma B N_\gamma F_{\gamma s} F_{\gamma d} F_{\gamma i}
 \end{aligned}
 \tag{1}$$

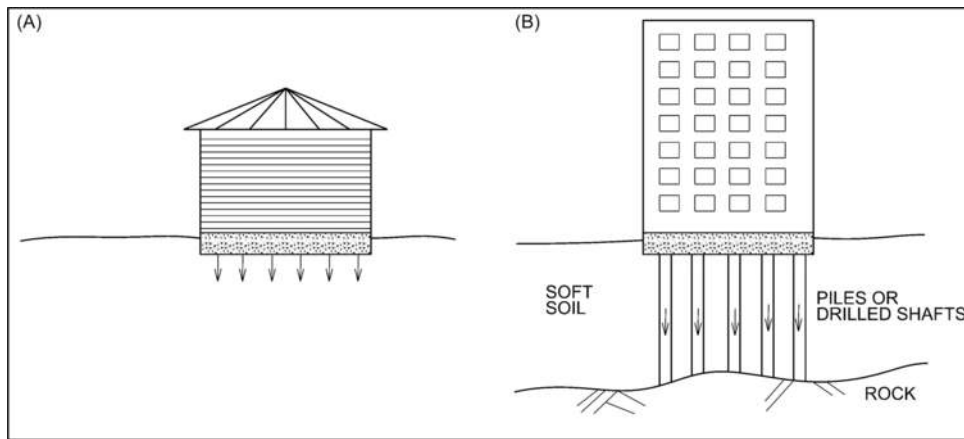

Fig. 3 Examples of (A) shallow foundations and (B) deep foundations.

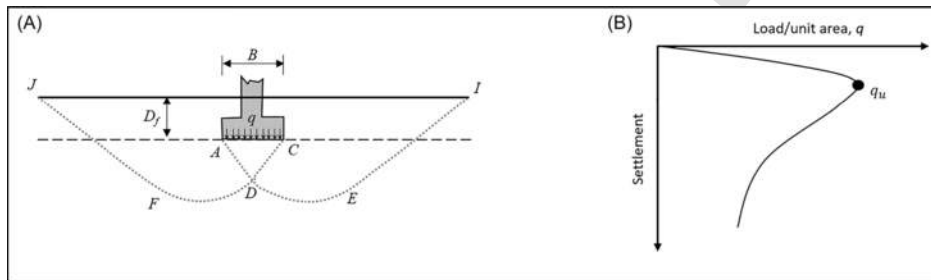

Fig. 4 Typical (A) cross-section of a strip footing and (B) load settlement curve.



Fig. 5 Transcona silo bearing capacity failure (Manitoba Historical Society, 2018).

where c' = cohesion, q_u = ultimate bearing capacity, γ = unit weight of soil, B = width of foundation (diameter for circular foundation), F_{cs} , F_{qs} , $F_{\gamma s}$ = shape factors, F_{cd} , F_{qd} , $F_{\gamma d}$ = depth factors, F_{ci} , F_{qi} , $F_{\gamma i}$ = load inclination factors, and N_c , N_q , N_γ = bearing capacity factors.

The shape factors, depth factors, and load inclination factors are determined from empirical relationships (De Beer, 1970; Hansen, 1970; Hanna and Meyerhof, 1981). The bearing capacity factors were determined by Prandtl (1921), Reissner (1924), and Vesic (1973). Using Eq. (1), the ultimate bearing capacity, q_u , can be estimated for a foundation design on a given soil. Given the large uncertainty that exists regarding designing with soils, a factor of safety greater than 3 is generally applied to q_u to arrive at the allowable bearing capacity (q_{all}) used in design where:

$$q_{all} = \frac{q_u}{FS} \quad (2)$$

Settlements

While Eqs. (1) and (2) provide a means for computing the allowable bearing capacity that would lead to catastrophic shear failure of the soil, it is often not a catastrophic failure that controls the design, but rather a service based limit on the allowable foundation settlements. As foundations settle, the structures they support may experience distress (especially in the case of differential settlements). The anticipated settlements of a shallow foundation must be calculated. A small portion of the settlement, termed elastic settlement, is nearly instantaneous. For saturated, fine-grained soils, the larger portion of the settlement, termed consolidation settlement, occurs gradually as the water is squeezed out of the soil under the new loads. The elastic settlement can be predicted using equations based on the theory of elasticity. For example, in the case of perfectly flexible foundations that conform to the deformed soil, the elastic settlement is given by Bowles (1987) as:

$$S_e = q_o (\alpha B') \frac{1 - \mu_s^2}{E_s} I_s I_f \quad (3)$$

where q_o = net applied pressure on the foundation, μ_s = Poisson's ratio of the soil, E_s = modulus of elasticity of the soil, B' = characteristic footing dimension, I_s , I_f = shape and depth factors, and α = factor related to location under the foundation.

The consolidation settlement can be obtained by examining the change in vertical stress that the soil experiences beneath the footing. Methods have been proposed for calculating the stress changes at depth beneath the footing (e.g., Boussinesq equation or influence diagrams). The stress increase at each level can then be determined, the change in void ratio (Δe) can be estimated using laboratory test data, and the total consolidation settlement can be computed from Eq. (4) as:

$$S_c = \sum \frac{\Delta e_i}{1 + e_0} z_i \quad (4)$$

The total settlement, S_T , is then given by Eq. (5) as:

$$S_T = S_e + S_c \quad (5)$$

If the total settlement computed using q_{all} exceeds the allowable settlement for the foundation, the load on the foundation must be reduced to a value q_s that meets the settlement requirement for the structure. The final design load for the foundation should always be the smaller value between q_{all} and q_s .

Deep foundations

The term *deep foundation* typically refers to either a driven pile foundation (Fig. 6A) or a drilled shaft foundation (Fig. 6B). Driven piles are typically pounded into the ground using a driving hammer as shown, although recent technological advancements have also made it possible to vibrate piles into the ground. Drilled shafts are constructed by auguring a hole in the ground, inserting reinforcing steel, and pouring concrete in the shaft. Both types of foundations are quite expensive to install but are often necessary to obtain the required load capacities, provide large horizontal resistance, provide pull-out resistance, or to ensure the foundation reaches through weak soil layers.

While shallow foundations rely entirely on soil bearing capacity to support a load, deep foundations provide resistance to vertical loads by two components: pile tip resistance (Q_p) and pile skin friction (Q_s) as shown on Fig. 6. The ultimate pile capacity, Q_u , is then given by:

$$Q_u = Q_s + Q_p \quad (6)$$

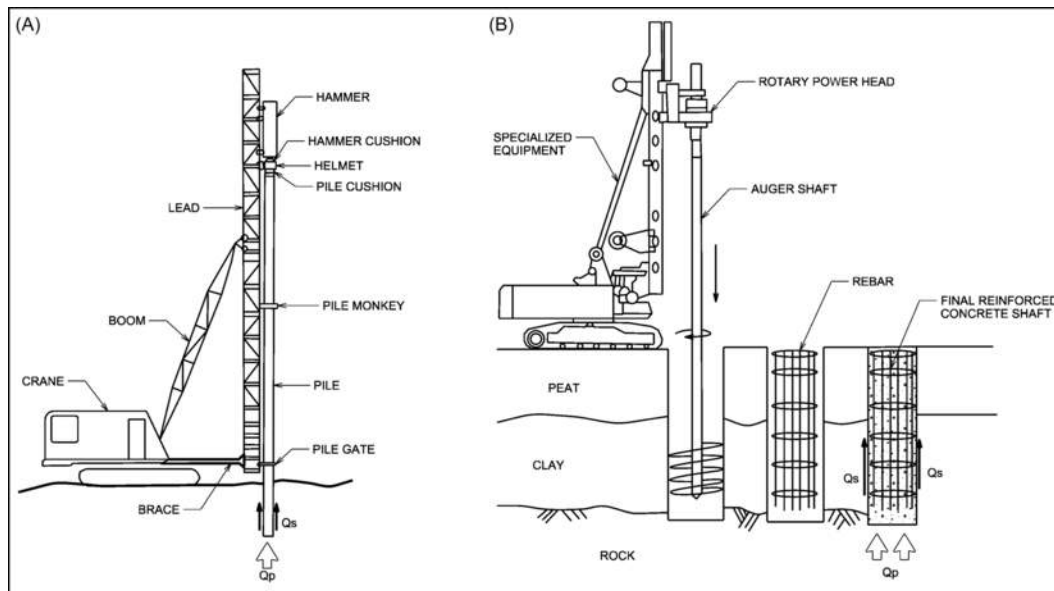

Fig. 6 Installation of deep foundations: (A) driven pile foundation and (B) drilled shaft foundation.

The allowable pile capacity used for design is obtained by dividing the ultimate pile capacity by a factor of safety:

$$Q_{all} = \frac{Q_u}{FS} \quad (7)$$

where the value of the factor of safety used generally ranges between 2.5 and 4.0 depending on the uncertainty surrounding the calculation of the ultimate load.

The value of Q_p is computed based on the bearing capacity of the soil at the pile tip. Estimates of Q_p can be obtained from equations similar in form to Eq. (1) (e.g., Vesic, 1973) or from correlations with in situ measurements such as SPT or CPT soundings (e.g., Meyerhof, 1976). The value of Q_s is computed as the sum of the side friction on the pile, given by:

$$Q_s = \sum p \Delta L f \quad (8)$$

where p = perimeter of the pipe section, ΔL = the incremental pile length corresponding to p and f , and f = unit frictional resistance between the pile shaft surface and the embedded soil. Numerous methods have been proposed for estimating f (e.g., Coyle and Castello, 1981; Meyerhof, 1976; Schmertmann, 1978). The method selected for estimating f should be derived from conditions similar to those for the design application. Once appropriate methods for computing Q_p and Q_s have been selected, the anticipated capacity of an individual pile or shaft can be calculated. To complete a foundation design, the geotechnical engineer determines how many piles or shaft elements are needed to support the load. Geotechnical and structural engineers then develop the final design.

As a final step, it is critical to test the installed piles in the field to ensure the actual pile capacity achieved meets the design expectations. This can be done through pile load tests in which the pile is physically loaded in the field to determine its actual load capacity.

Slopes and Embankments

Slope failures, both in manmade embankments and naturally occurring slopes, pose a significant hazard to human activities. Manmade embankments are often constructed as part of transportation infrastructure, such as for highways or railways. Further, when constructing roads and railways, it is often necessary to cut into natural slopes, thereby steepening them and reducing the overall stability. For these cut slopes, and natural slopes in general, it is usually necessary to perform calculations to ensure the slopes remain stable. Large movements in slopes and embankments due to slope failures can have devastating consequences (Fig. 7A).

To assess the stability of slopes and embankments, the weakest failure plane within the slope must be identified. As such, it is critical that careful site investigation has been undertaken to identify the weakest soils. After the soil profile has been carefully developed, the stability of the slope is often evaluated using limit equilibrium techniques that assess the force and/or moment equilibrium of various failure masses as shown in Fig. 7B. For simple geometries, the stresses and corresponding shear strengths may be assessed analytically with a single slip surface. For more complex geometries, the failure mass is broken up into vertical slices (called the method of

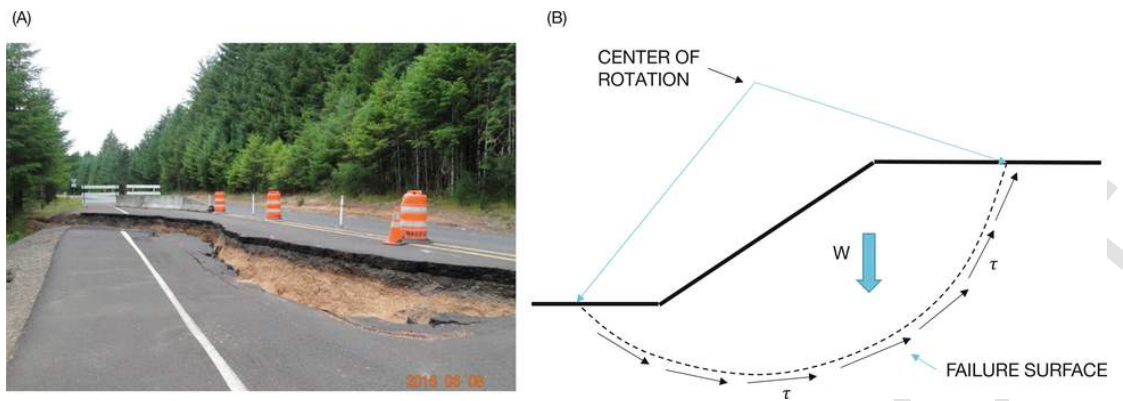

Fig. 7 Images of (A) a highway embankment slope failure (FHWA, 2019) and (B) the corresponding geotechnical analysis.

slices), and the stress and soil strength on each slice are assessed. Numerous methods have been developed for this type of analysis (see Duncan et al., 2014). To find the critical slip surface, this analysis procedure is repeated for all possible slip surfaces to find the most critical failure plane. If the available shear strength along the critical failure surface exceeds the driving forces (soil weight), the slope is determined to be stable.

Dams and Levees

While compacted earth embankment dams and levees may look like highway embankments, they are quite different since they must retain water for extended periods. The extended presence of water on these types of embankments can lead to erosion of the embankment. Erosion of the embankment can occur due to water overtopping the embankment, or it can occur internal to the embankment due to water seeping or leaking through the embankment fill. As shown in Table 2, approximately half of historic embankment dam failures, defined as uncontrolled release of the reservoir, are caused by overtopping; the remaining half result from internal erosion. All other causes of failure constitute only a very small portion of historically observed failures. This means that, unlike slopes and transportation embankments, slope stability is not the primary issue of concern. Slope stability must still be assessed, but erosion is by far an issue of greater concern for dams and levees.

Overtopping of embankments, while a significant cause of failure, is more of a hydraulic and hydrologic issue than a geotechnical issue and will not be discussed further. Internal erosion, on the other hand, is a geotechnical issue and is of major concern for embankment dams and levees. To prevent internal erosion of an embankment, it is necessary to provide filters and drains in the dam section (Fig. 8). The filters and drains prevent material from eroding while simultaneously conveying the seepage and/or leakage out of the dam section in a safe and controlled manner. For proper function, the gradation of the filter and drain material must be selected such that it is fine enough to prevent adjacent material from moving, but also coarse enough to safely convey the water out of the dam at relatively low hydraulic gradients. These conditions are ensured by selecting gradations such that:

Table 2 Causes of embankment dam failures (Foster et al., 2000).

Failure Mode:	Internal Erosion	Overtopping	Other
Percentage:	48	46	6

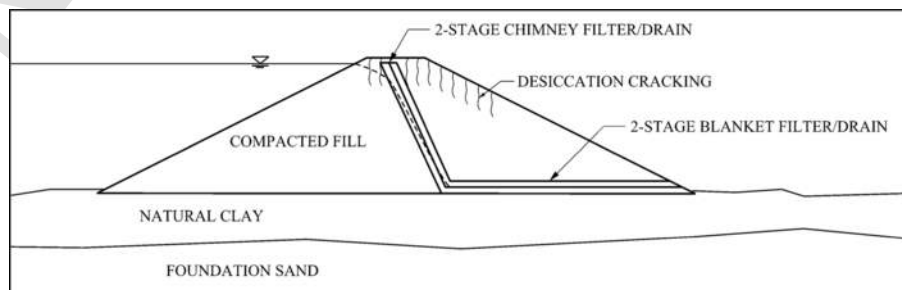

Fig. 8 Cross section of an earth dam designed with modern filters and drains.

$$\frac{d_{15F}}{d_{85B}} < 4 \text{ and } \frac{d_{15F}}{d_{15B}} > 4 \quad (9)$$

where d_{15F} is the particle diameter for which 15% of the filter material is finer, d_{85B} is the particle diameter for which 85% of the base soil (soil being filtered) is finer, and d_{15B} is the particle diameter for which 15% of the base soil is finer. The first requirement in Eq. (9) ensures that the filter material is fine enough to prevent the base material (adjacent material) from eroding. The second requirement ensures the material is pervious enough to convey away the seepage. If an entire dam cross section is protected by filters and drains as shown in Fig. 8, the dam will likely perform satisfactorily (Fry, 2016).

Retaining Walls

In some cases, there is not enough space at a site to grade a slope to a stable configuration. In these instances, it is necessary to construct a retaining structure that will hold the soil behind it in place. Numerous types of retaining walls are illustrated in Fig. 9. Gravity retaining walls consist of a large concrete wall with enough mass to retain the earth using the wall's own self weight. Piling walls use the lateral resistance of a pile to retain the earth. Cantilever walls are designed to use some of the soil's self-weight to resist the lateral earth pressures. Lastly, anchored retaining walls use the resistance of an anchor to develop the force necessary for retaining the earth.

Regardless of the type of retaining wall, the wall must be designed such that it doesn't move excessively in any direction. A retaining wall must be designed considering the following possible failure modes:

- (i) Bearing capacity failure—The wall base pressure must not exceed the ultimate bearing capacity of the soil.
- (ii) Lateral sliding failure—The lateral resistance of the wall, whether developed through sliding friction, anchor resistance, or lateral pile capacity, must be adequate to withstand the lateral earth pressures it is retaining.
- (iii) Wall rotational failure—The wall must be designed such that the lateral earth pressure pushing on the wall is not capable of tipping the wall over.
- (iv) Global stability—The wall must be determined to be stable along any failure surface through surrounding soil that encompasses the wall. Global stability is checked by comparing available shear strength along all possible failure surfaces to the anticipated loads.

The allowable bearing pressure beneath the wall can be assessed using the same approach as used for shallow foundations. If the wall contact pressure remains less than calculated using Eqs. (1) and (2), the wall is satisfactory with respect to bearing capacity. For sliding and rotational failures, it is necessary to estimate the lateral earth pressures that will be applied against the wall. For most walls, some movement is allowed such that the wall can be designed for active earth pressures. The active earth pressure, σ'_a , acting on the wall can be computed as:

$$\sigma'_a = \sigma'_o K_a - 2c' \sqrt{K_a} \quad (10)$$

where σ'_o = vertical effective stress at a given point, K_a = active earth pressure coefficient, and c' = effective soil cohesion.

Methods for determining K_a have been derived by many (e.g., Rankine and Coulomb earth pressure theories). Once the lateral earth pressure has been determined along the back of a wall face, the resultant earth pressure force can be calculated, and the wall can be checked for sliding and rotational stability using principles of static equilibrium.

In addition to the structural walls shown, it is also possible to use mechanically stabilized earth (MSE) walls. A schematic illustration of a MSE wall is shown in Fig. 10. The MSE wall consists of soil layers compacted around strips or panels of reinforcing elements (typically plastic geogrids, geosynthetic fabrics, or steel reinforcing strips). The reinforcing elements are attached to a facing

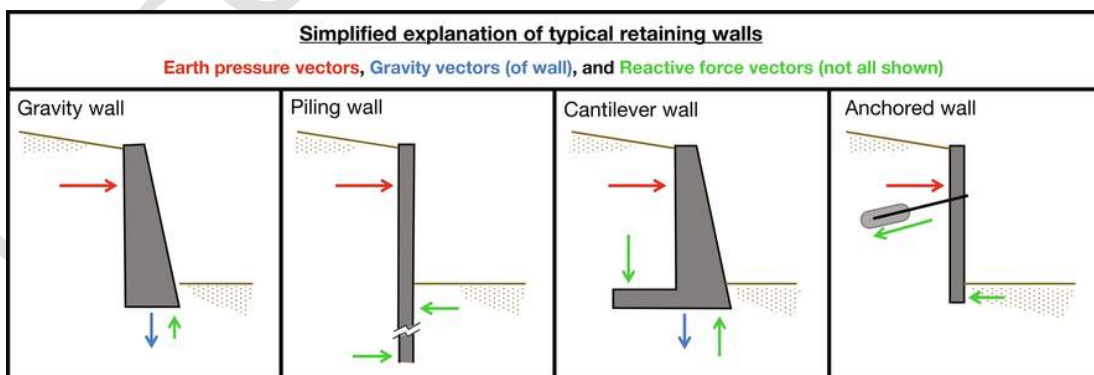

Fig. 9 Types of earth retaining walls. Source: Ingolfson/Wikimedia Commons/Public Domain.

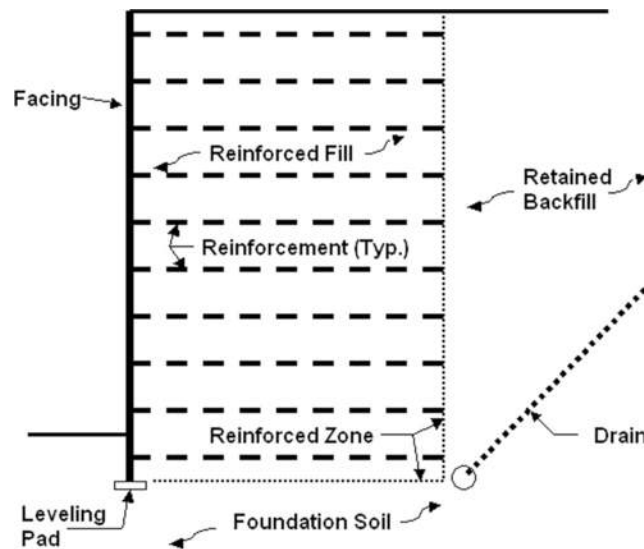

Fig. 10 Schematic of a mechanically stabilized earth (MSE) wall (Berg et al., 2009).

system. Together, the reinforced soil and facing system act as a strong, coherent mass that can be assessed for the three wall failure modes previously discussed. However, in addition to bearing capacity, sliding, and rotational stability, the MSE wall must also be assessed for internal stability to ensure the loads on the reinforcements do not exceed the tensile capacity or pullout resistance of the reinforcement (see e.g., Das, 2007). MSE walls have become popular as they are economical, easy to construct, and quite ductile. The ductility of an MSE wall makes them perform very well under dynamic loading, such as occurs during earthquakes.

Dewatering

In addition to designing an actual foundation, slope, or wall, it is necessary to give substantial thought to constructability issues. In many cases (e.g., bridge foundations, deep building foundations), the designed structure will be placed well below the water table. To construct the structure in a dry environment, it is necessary to dewater the construction site. Typically, dewatering is required when (i) constructing a structure in an existing body of water or (ii) while advancing an excavation below the water table. In the first case, it is often necessary to also build a cofferdam to isolate the construction site from the body of water.

To dewater a site, well points are typically installed as shown in Fig. 11. The groundwater is pumped out of the well points resulting in a local drawdown of the water table. The extent of the drawdown depends on many factors such as the well point design, pump capacity, and hydraulic conductivity of the surrounding soil. For simple cases, analytical solutions can be used to estimate the dewatering design (Preene and Rosser, 2012). Computer programs for assessing groundwater flow can also be used to aid in the design of dewatering systems.

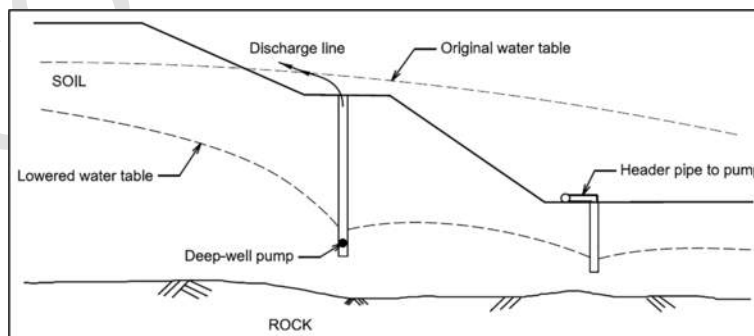

Fig. 11 Schematic of a dewatering system being used to dewater an excavation.

Tunneling

With increasing urbanization, more and more transportation infrastructure is being relocated underground in large diameter tunnels. These tunnels are being constructed in a variety of ground conditions ranging from soft clay (e.g., Chicago subway) to crystalline rock (e.g., Eisenhower tunnel). Regardless of ground conditions, geotechnical engineers must control groundwater levels in the tunnel while simultaneously minimizing any deformations that result from creating an open void deep in the earth. In certain soil conditions, such as hard, competent rock, a tunnel may not require any type of internal structure to stabilize the tunnel walls and minimize surrounding deformation. However, in conditions such as soft soil, the great pressures from the overlying earth materials may need to be restrained by high strength steel and concrete tunnel linings to prevent tunnel collapse and large deformation. For more details on engineering aspects of tunnel construction, see **Hung et al. (2009)**.

Offshore Structures

Over the past six decades, offshore geotechnical engineering has gained in importance due to the substantial amount of oil and gas infrastructure that has been constructed, much of it offshore. There are currently over 10,000 offshore platforms (**Dean, 2010**). While the principals of soil mechanics are unchanged in an offshore environment, there are some stark differences between onshore and offshore engineering. **Dean (2010)** lists the following items as the main differences for offshore geotechnics:

- The clients and regulatory bodies are different,
- Many offshore structures are large (many stand over 100 m above the seabed, and some are considerably taller),
- The design life of an offshore structure is typically in the range 25–50 years,
- Most offshore structures are constructed in parts onshore, and are assembled offshore,
- Ground improvement is feasible offshore, but rather more expensive,
- A larger range of geohazards can affect offshore structures,
- Offshore environmental loads include high lateral loads,
- Cyclic loading can be a major or even dominant design issue (waves and wind),
- The environmental and financial cost of failure can be higher.

In addition to these differences, it is easily recognized that the offshore environment greatly complicates site investigation and sampling due to the great depth of water that is often overlying the site. Often, robotic submersible cone penetration rigs or drill rigs are sent to the sea floor to carry out investigations. The cost of routine investigations in an offshore environment is many times the cost of that for an equivalent onshore project. For further details on offshore geotechnics, the interested reader is referred to **Dean (2010)**.

Soil Dynamics

Most geotechnical engineering issues are controlled by static loads or loads that are assumed to be static. Three subsets of geotechnical engineering that involve dynamic loads are: (i) roads and highways, (ii) earthquake loading issues and (iii) machine vibrations. In the case of roads and highways, the dynamic loads from vehicle traffic primarily only influence the design of the pavement section. For the pavement design, the loads are quantified as “Equivalent Single Axle Loads” to allow pavement fatigue and wear to be quantified. Earthquake engineering analysis is usually performed on bridges, tall buildings, high retaining walls, and dams where failure would result in substantial loss of life. From an earthquake engineering point of view, several elements are critical. One is depth to rock, as that usually has a significant influence on the natural frequency of the site. Natural frequency is defined as the frequency at which a system shakes/vibrates or oscillates when not subjected to a continuous or repeated external force. The second critical factor is the presence of loose sands or silty sands. The third critical factor is determining the location of the water table as loose saturated sands and silty sands are problematic materials, if subjected to strong shaking. These saturated soils, if not adequately dense, can liquefy and lose strength as a result of earthquake shaking. Such strength loss can often lead to large uncontrolled deformations. The geotechnical engineer works with geologists and seismologists to develop a suite of design earthquakes for the site and structure, and these motions are used as input to dynamic analyses to assure that the site/structure will perform satisfactorily, and all displacements will be tolerable.

Industrial complexes that involve the operation of heavy machinery (the auto industry) and/or super-sensitive elements sometimes have machine vibration issues. The critical elements here are (i) the machine and foundation mass, as that usually controls the natural frequency and (ii) the operating frequency of the machine. Often the solution to vibration problems is to change the natural frequency of the system by adding mass (see e.g., **Richart et al., 1970**).

Rockfalls and Landslides

Rockfalls frequently occur along transportation corridors where deep cuts have been made into rock slopes. When a rockfall occurs, it can cause substantial damage to roads and other transportation infrastructure. Furthermore, rockfalls can cause routes to be shut down entirely, potentially costing millions of dollars per event. Similarly, landslides often occur near anthropogenic changes in the landscape where soil has been removed or placed due to land development activities. From 2004 to 2010, 2620 fatal landslides occurred worldwide causing a total of 32,322 fatalities (**Petley, 2012**). Given the frequency and severity of consequences, it is obvious that both rockfalls and landslides are issues that must be assessed and managed.

Rockfalls typically occur in rock cut slopes when rock blocks become dislodged by weather, flowing water, or due to the surrounding rocks and soil being eroded. Because of the irregular, unpredictable nature of rock joints and weathering patterns, rockfalls cannot be precisely predicted. Instead, sites that are prone to rockfalls (relatively speaking) can be qualitatively identified using systems such as the Rockfall Hazard Rating System (Pierson and Vickle, 1993). Once higher risk sites have been identified, responsible agencies can design and install rockfall mitigation systems as resources permit. Examples of rockfall mitigation systems include catch ditches, draped steel meshes, and rockfall fences. Mitigation systems are usually designed using methods or models based on empirical data or calibrated to actual rockfalls.

As with rockfalls, landslide hazards are also assessed through categorical, semi-qualitative risk assessment procedures that incorporate the likelihood of landslides occurring and the consequences of a landslide. For high risk areas, risks are typically managed through changes in land use zoning and risk communication (Fell et al., 2008).

Ground Improvement

Ground improvement, or ground modification, is defined as the alteration of site foundation soils or project earth structures to provide better performance under design and/or operational loading conditions (Schaefer et al., 2012). Ground improvement is necessary when poor soil conditions are encountered for the purpose at hand. While the poor soil conditions could readily be dealt with by excavating and replacing the soil, or perhaps by using deep foundations, it is often more cost effective to simply improve the soil in place through some type of treatment. As noted by Schaefer et al. (2012), ground modification typically serves one or more of the following primary functions:

- Increase shear strength and bearing capacity,
- Increase density,
- Decrease permeability,
- Control deformations,
- Increase drainage,
- Accelerate consolidation,
- Decrease imposed loads,
- Provide lateral stability,
- Increase resistance to liquefaction,
- Transfer embankment loads to more competent subsurface layers.

Numerous ground improvement technologies are available (see Schaefer et al., 2012). A few examples of commonly applied technologies are deep dynamic compaction, vibro compaction, and deep soil mixing (Fig. 12). Dynamic compaction consists of repeatedly dropping a heavy weight on soil to densify the soil at depth. Vibration compaction is usually used for loose, sandy soils and consists of vibrating a column in the soil to densify a zone. Deep soil mixing consists of auguring columns of soil, and mixing the soil with additives (often cement) to strengthen the soil.

Construction

As part of geotechnical design, numerous assumptions are made about the site conditions and soil properties. In order to ensure a structure performs as designed, it is necessary to carefully validate the design assumptions by observations, measurements, and testing during construction. The following sections briefly mention some aspects of quality control measures that are taken done during construction to ensure the final structure meets the design expectations.



Fig. 12 Examples of soil improvement technologies: (A) deep dynamic compaction, (B) vibro compaction, and (C) deep soil mixing. Photographs courtesy of Keller.

Foundation Inspection

For large critical projects, the foundation must be inspected to ensure compliance with design assumptions. Often, foundation preparation work must also be undertaken to bring the foundation up to design expectations. During a foundation inspection, engineers ensure that the materials present are as anticipated to check that the actual conditions are in line with design assumptions. If unfavorable conditions are encountered, it may be necessary either to excavate more material than anticipated or apply site improvement techniques.

Earthwork Control

As embankment fill is placed, it is imperative to ensure that (i) the correct materials are being placed and (ii) the fill is being constructed at the correct water content and density. Samples of fill material are taken at regular intervals in order to run particle size analysis and water content tests on the fill. To assess the density of the fill, various destructive and nondestructive tests can be conducted. A common nondestructive test used for measuring soil density is the nuclear density gage. The nuclear density gage must be calibrated for each and every site, but is convenient as it provides good estimates of both the soil density and water content.

Erosion Control and Drainage

With any earthwork operation, bare soils will be exposed to the elements. Unfavorable weather, either in the form of rain or extremely dry and windy conditions, can cause excessive erosion of the bare soils. Not only can this result in degradation of the newly constructed works, it can also be an environmental problem due to the high sediment loads that can be transported off a construction site. As a result, plans and specifications often require contractors to implement measures capable of controlling both storm water and sediment loads. Examples of sediment retention devices include silt fences and straw wattles (Fig. 13). For a detailed description of erosion and sediment control design, refer to CALTRANS (2003).

Future Directions

Education

First, consider the need for educating geotechnical engineer in the United States, which is not unlike the situation worldwide. Today, the educational entry-level requirement is a Master's Degree (MS). This is because of the proliferation of knowledge requires more courses while the required number of hours to graduate with a typical undergraduate degree has decreased for most accredited programs. In the U.S. students might take one introductory course in geotechnical engineering in their undergraduate study and many take none. Thus, an additional year or two of graduate study provides course work with a geotechnical focus on topics such as deep and shallow foundations, soil properties, consolidation and settlement, soil dynamics and engineering geology. Currently, most education beyond a MS program focuses on a Doctor of Philosophy (PhD). This degree is geared to teaching and research and surely prepares one to enter academia.



Fig. 13 Photograph of straw wattle used to control soil erosion during construction.

The authors consider that there is an increased need for the Doctor of Engineering (DE) degree that focuses more on the practice of geotechnical engineering.

Currently most states in the USA require an Accreditation Board for Engineering and Technology (ABET) accredited BS degree and 4 years of experience, supervised by a professional engineer; or 2 years of supervised experience and a MS degree before an individual can sit for the examination to become a *Registered Professional Engineer*. These requirements should be more rigorous, and the authors would encourage state Boards of Registration to move in the direction of specialty registration, requiring an MS degree along with experience before becoming a registered geotechnical engineer.

There is and will be a continuing need for a large cadre of well-educated and trained engineering technicians. The engineering technicians that are envisioned here should have a college education and be trained in various aspects of geotechnical engineering including, for example: soil sampling, laboratory testing, computer analyses, field inspection, construction monitoring, etc. (Marcuson, 1988; Marcuson et al., 1991).

Technology

Modern computer technology has surely added value to the geotechnical engineer. For example, computers can be used to display and visualize the subsurface conditions in two and three dimensions. Computer programs now exist that allow one to conduct 2- and 3-dimensional slope stability, seepage, and deformation analyses. Future advances in computational and visualization capability will surely change and improve the practice of geotechnical engineering further. For example, the authors consider that there is still much room for improvement in the use of computers for 3-D visualization of subsurface conditions, the use of “big data” in geotechnics, application of machine learning algorithms, and automated analysis of uncertainty and risk.

Now looking to the future of site characterization, future cone penetration tests and their rod strings likely will carry multiple geophysical/mechanical tools for measurement of soil mechanical properties. The key to improved spatial resolution in geophysical surveys will be a development of ways to emplace dense arrays of sensors on the ground surface and underground, and the use of tomographic methods to analyze these data.

Conclusions

Geotechnical engineering is a sub-discipline of civil engineering and can be defined as the use of earth material (soil and rock) for improving and defending society and life. Until about the last 100 years geotechnical engineering was largely empirical and based on observation and careful reflection. Remarkable scientific advancement in this specialty within civil engineering has been achieved in the post-World War II era and continues today with the aid of high-performance computers, sensors, data visualization, and advanced soil testing.

Geotechnical engineering is a critical component of nearly all infrastructure related endeavors whether they be civilian or military. This is because everything except space structures such as satellites is founded on the earth. Furthermore, if there are issues with the foundation, then the entire structure is in trouble. Therefore, geotechnical engineers play a critical role in every constructed project.

Geotechnical engineering relies on the continuous application of engineering judgment. This judgment can be best developed by careful study of past successes and failures, and years of experience. Through continued education and mentorship, experiences are passed from one generation to the next leading to continued advancement of the profession.

References

- Berg, R.R., Christopher, B.R., Samtani, N.C., 2009. Design of Mechanically Stabilized Earth Walls and Reinforced Soil Slopes. Technical Report FHWA-NHI-10-024. Federal Highway Administration, Washington, D.C.
- Bishop, A.W., Henkel, D.J., 1957. The Measurement of Soil Properties in the Triaxial Test. Edward Arnold (Publishers) Ltd..
- Bowles, J.E., 1987. Elastic foundation settlements on sand deposits. *Journal of Geotechnical Engineering* 113 (8), 846–860.
- CALTRANS, 2003. Caltrans Erosion Control New Technology Report. California Department of Transportation, Available at: http://www.dot.ca.gov/hq/env/stormwater/special/newsetup/_pdfs/erosion/CTSW-RT-03-049.pdf.
- Coyle, H.M., Castello, R.R., 1981. New design correlations for piles in sand. *Journal of the Geotechnical Engineering Division, ASCE* 107 (GT7), 965–986.
- Das, B.M., 1979. *Introduction to Soil Mechanics*. Iowa State University Press.
- Das, B.M., 2007. *Principles of Foundation Engineering*, 6th edn. Thomson.
- De Beer, E.E., 1970. Experimental determination of the shape factors and bearing capacity factors of sand. *Geotechnique* 20 (4), 387–411.
- Dean, E.T., 2010. *Offshore Geotechnical Engineering*. Thomas Telford.
- Duncan, J.M., Wright, S.G., Brandon, T.L., 2014. *Soil Strength and Slope Stability*. John Wiley & Sons.
- Dunncliff, J., Green, G.E., 1993. *Geotechnical Instrumentation for Monitoring Field Performance*. John Wiley & Sons.
- Fell, R., MacGregor, P., Stapledon, D., Bell, G., Foster, M., 2005. *Geotechnical Engineering of Dams*. CRC press.
- Fell, R., Corominas, J., Bonnard, C., Cascini, L., Leroy, E., Savage, W., 2008. Guidelines for landslide susceptibility, hazard and risk zoning for land use planning. *Engineering Geology* 102 (3), 85–98.
- FHWA, 2019. Hagg Lake Perimeter Road Project. Federal Highways Administration, Vancouver, WA, Article retrieved from: <https://flh.fhwa.dot.gov/projects/or/hagg-lake/>.
- Foster, M., Fell, R., Spannagle, M., 2000. The statistics of embankment dam failures and accidents. *Canadian Geotechnical Journal* 37 (5), 1000–1024.
- Fry, J.J., 2016. Lessons on internal erosion in embankment dams from failures and physical models. In: *Scour and Erosion: Proceedings of the 8th International Conference on Scour and Erosion*. Oxford, UK, 12-15 September. CRC Press.

- Hanna, A.M., Meyerhof, G.G., 1981. Experimental evaluation of bearing capacity of footings subjected to inclined loads. *Canadian Geotechnical Journal* 18 (4), 599–603.
- Hansen, J.B., 1970. A Revised and Extended Formula for Bearing Capacity. Bulletin 28. Danish Geotechnical Institute, Copenhagen.
- Holtz, R.D., Kovacs, W.D., Sheahan, T.C., 2011. *An Introduction to Geotechnical Engineering*, 2nd edn. Prentice-Hall Inc..
- Hung, C.J., Monsees, J., Munfah, N., Wisniewski, J., 2009. *Technical Manual for Design and Construction of Road Tunnels—Civil Elements*. Publication Number FHWA-NHI-10-034. Federal Highway Administration, Reston, VA.
- Hunt, R.E., 1984. *Geotechnical Engineering Investigation Manual* (No. 624.151 H86). McGraw-Hill, New York.
- Kerisel, J., 1985. History of geotechnical engineering up until 1700. In: *Golden Jubilee Volume, Proceedings of the 11th International Conference on Soil Mechanics and Foundation Engineering*. AA Balkema, San Francisco, CA.
- Manitoba Historical Society, 2018. *Historical Sites of Manitoba: Parrish & Heimbecker Grain Elevator*. In: <http://www.mhs.mb.ca/docs/sites/northtransconaelevator.shtml>, (Retrieved 15 September 2019).
- Marcuson III, W.F., 1988. Plan for quality growth in engineering education. *ASCE Journal of Professional Issues in Engineering* 114 (1).
- Marcuson III, W.F., Dobry, R., Nelson, J.D., Woods, R.D., Youd, T.L., 1991. Issues in geotechnical engineering education. *Journal of Professional Issues in Engineering Education and Practice* 117 (1).
- Meyerhof, G.G., 1963. Some recent research on the bearing capacity of foundations. *Canadian Geotechnical Journal* 1 (1), 16–26.
- Meyerhof, G.G., 1976. Bearing capacity and settlement of pile foundations. *Journal of the Geotechnical Engineering Division, ASCE* 100 (GT7), 709–747.
- Peck, R.B., 1985. The last sixty years. In: *Golden Jubilee Volume, Proceedings of the 11th International Conference on Soil Mechanics and Foundation Engineering*, San Francisco, CA. AA Balkema.
- Petley, D., 2012. Global patterns of loss of life from landslides. *Geology* 40 (10), 927–930.
- Pierson, L.A., Vickle, R.V., 1993. *Rockfall Hazard Rating System—Participants' Manual*, No. FHWA-SA-93-057.
- Prandtl, L., 1921. Hauptaufsätze: Über die eindringungsfestigkeit (härte) plastischer baustoffe und die festigkeit von schneiden. *Zeitschrift für Angewandte Mathematik und Mechanik* 1 (1), 15–20.
- Preene, M., Rosser, M., 2012. *Groundwater Lowering in Construction*. CRC Press, London.
- Reissner, H., 1924. Zum erddruckproblem. In: *Proc. 1st Int. Congress for Applied Mechanics*. Delft, the Netherlands.
- Richart, F.E., Hall, J.R., Woods, R.D., 1970. *Vibrations of Soils and Foundations*. Prentice-Hall Inc..
- Schaefer, V.R., Mitchell, J.K., Berg, R.R., Filz, G.M., Douglas, S.C., 2012. Ground improvement in the 21st century: A comprehensive web-based information system. In: *Rollins, K., Zekkos, D. (Eds.), Geotechnical Engineering State of the Art and Practice*. pp. 272–293, ASCE Geotechnical Special Pub. No 226.
- Schmertmann, J.H., 1978. *Guidelines for Cone Penetration Test: Performance and Design*. Report FHWA-TS-78-209. Federal Highway Administration, Washington, DC.
- Skempton, A.W., 1985. A history of soil properties, 1717–1927. In: *Golden Jubilee Volume, Proceedings of the 11th International Conference on Soil Mechanics and Foundation Engineering*, San Francisco, CA. AA Balkema.
- USBR and USACE, 2018. *Internal Erosion Risks for Embankments and Foundations*. In: <https://www.usbr.gov/ssle/damsafety/risk/BestPractices/Chapters/D-6-20180715.pdf>.
- Vesic, A.S., 1973. Analysis of ultimate loads of shallow foundations. *Journal of the Soil Mechanics and Foundations Division* 99 (1).

Further Reading

- Das, B.M., 2007. *Principles of Foundation Engineering*, 6th edn. Thomson.
- Holtz, R.D., Kovacs, W.D., Sheahan, T.C., 2011. *An Introduction to Geotechnical Engineering*, 2nd edn. Prentice-Hall Inc..
- Lambe, T.W., Whitman, R.V., 1969. *Soil Mechanics*. John Wiley and Sons, 553 pp.
- Richart, F.E., Hall, J.R., Woods, R.D., 1970. *Vibrations of Soils and Foundations*. Prentice-Hall Inc..
- Fell, R., MacGregor, P., Stapledon, D., Bell, G., Foster, M., 2005. *Geotechnical Engineering of Dams*. CRC Press.

Glossary

- Consolidation** The gradual decrease in volume of soil in response to an increase in pressure resulting from escape of water.
- Effective stress** The amount of compressive stress carried by the solid particles in a soil matrix.
- Foundation** A structural element that transfers structural loads to the underlying ground.
- Geophysics** The natural science concerned with physical processes and properties of the earth; in this context, geophysical methods make use of physical properties of soil and rock to investigate material profiles in the ground.
- Hydraulic conductivity** The property that quantifies the ease with which water can flow through the soil.
- Normal stress** The component of stress that acts perpendicular to a plane.
- Porosity** The percentage of void space (air and water) within a soil matrix.
- Seismology** The branch of science concerned with earthquakes and related phenomena.
- Shear stress** The component of stress that acts parallel to a plane.
- Shear strength** A physical quantity denoting the magnitude of shear stress a material can withstand without failing.
- Stress** A physical quantity representing the force per unit area acting over a surface.
- Soil** A mixture of solid particles (commonly mineral grains), water, air, and sometimes organic matter.



B.A. Robbins is a research civil engineer at the U.S. Army Engineer Research and Development Center, Geotechnical and Structures Laboratory with expertise in geotechnical engineering, dam and levee engineering, soil mechanics, numerical methods, and risk analysis. He recently served on the Executive Board of GEOSNet, an international professional organization focused on advancing concepts of geotechnical safety and risk. He was a 2019 recipient of the International Society for Soil Mechanics and Geotechnical Engineering Bright Spark Lecture Award and a 2010 recipient of the U.S. Department of Defense SMART Scholarship award.



I.J. Stephens is a geotechnical engineer who works for the U.S. Bureau of Reclamation overseeing dam safety projects at hydroelectric dams. Prior to his current position he worked as a research engineer at the U.S. Army Engineer Research and Development Center focused on research regarding dams and levees. Mr. Stephens has extensive experience in geotechnical site investigations, soil mechanics and laboratory testing of soils. He has his M.S. and B.S. degrees from Utah State University in Civil and Environmental Engineering.



W.F. Marcuson III was President of the American Society of Civil Engineers (ASCE) and is one of the nation's leading civil engineers. He has received five national awards from ASCE, including the Norman Medal, civil engineering's oldest honor. In 1995 he was honored by the National Society of Professional Engineers as their Federal Engineer of the Year. He is the only engineer to be named the Corps of Engineer's Engineer of the Year twice (1981 and 1995), and he was honored by the Corps as their Civilian of the Year in 1997. He was elected to the National Academy of Engineering in 1996 and to the National Academy of Construction in 2015 for his contributions to the design and analysis of embankment dams.